

Fixed Magnification Lens 2/3" Format

Item No.MRL2000

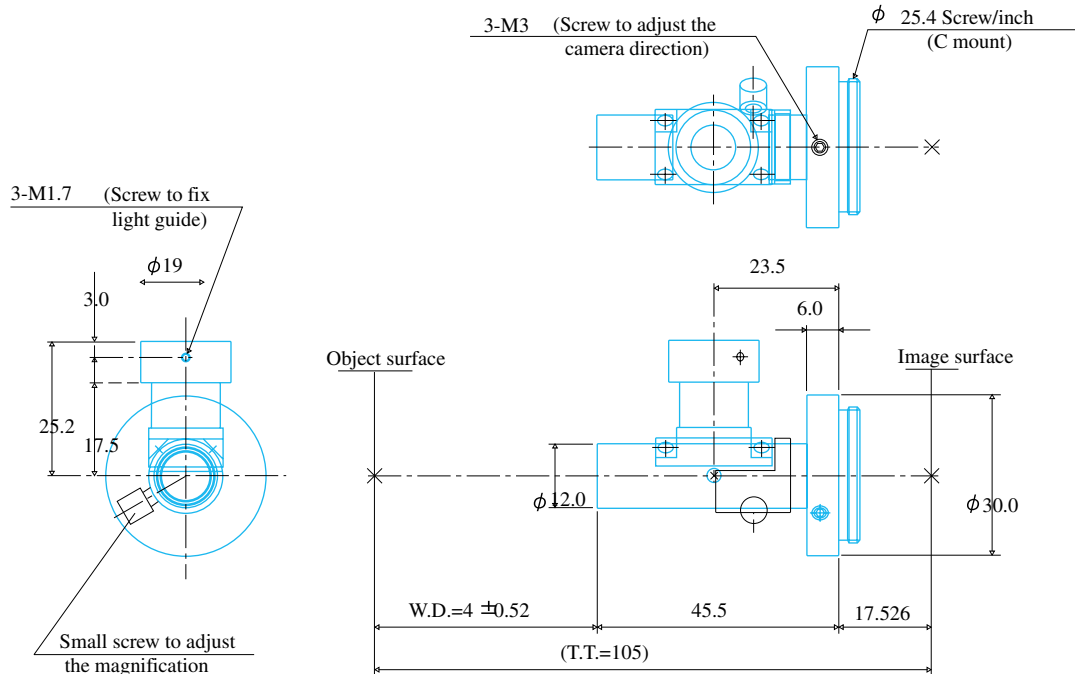

ITEM NO.	MRL2000
W.D.	42 - 35 (mm)
MAGNIFICATION	x2.0 - 2.4
APERTURE	F17 - 20
DEPTH OF FIELD	+/-0.20 (x2.00) (mm)
OBJECT SIZE	2.4 x 3.2 - 2.0 x 2.7 (mm)
IMAGE SIZE	4.8 x 6.4 (mm)
RESOLUTION POWER	7 - (μ m)
NA	0.059 (%)
TV DISTORTION	0.2 (%)
NOTES	Coaxial , Telecentric Lens

GOYO OPTICAL Inc.

Japanese Office

3-8-31 HAMAZAKI,
 ASAKA,
 SAITAMA 351-0033,
 JAPAN,
 TEL:048-474-2235
 FAX:048-474-7373
 E-MAIL:info@goyooptical.com

German Office

KURHAUSSTR,3
 ROOM N'19
 D-55543 BAD KREUZNACH
 GERMANY
 TEL:0671-4822255
 FAX:0671-43603
 E-MAIL:info@goyooptical.com