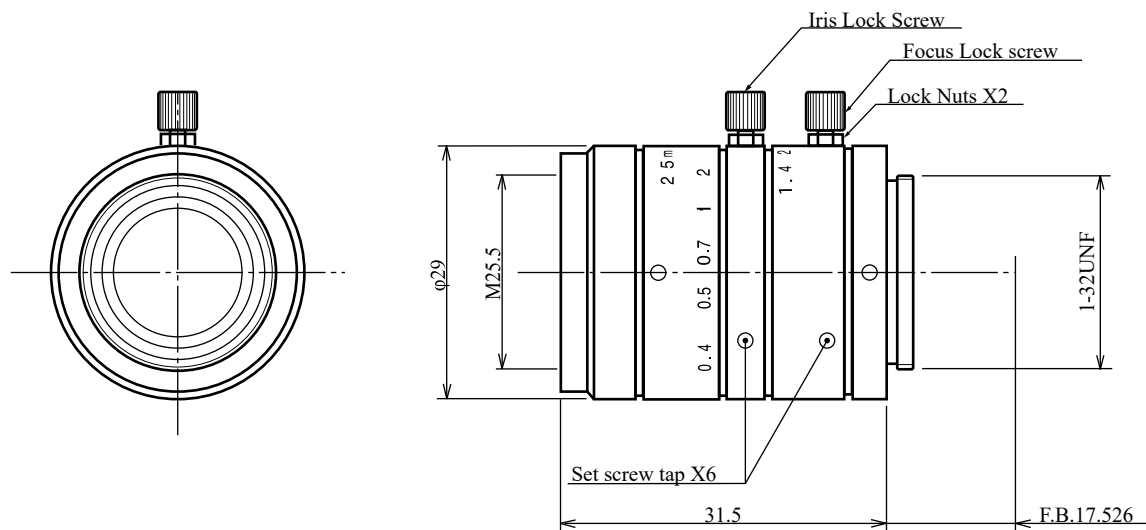

High Resolution Lenses

Item No. GMTHR32514MCN-1

ITEM NO.		GMTHR32514MCN-1
Focal Length		25.0 (mm)
Iris Range		F1.4 - 16
Angle of View (H x V x D)	1/2"	14.6° x 11.0° x 18.2°
	2/3"	21.1° x 15.1° x 25.0°
MOD		0.25 (m)
Filter Thread		M=25.5, P=0.5
Dimension (D x L)		φ 29 x 32 (mm)
Weight		50 (g)
Notes		3megapixel